

## Studio Monitors

# NEKKST K8

Audiophile Bi-Amped 8" Studio Monitor with Advanced Waveguide Technology

- Ultra-linear 150-Watt reference-class studio monitor
- Designed by renowned acoustic icon Keith Klawitter, founder of KRK\*
- Advanced Waveguide technology creates ultimate acoustic dispersion and extremely large "sweet zone"
- True bi-amping mode with 2 separate amplifiers for ultimate sound reproduction
- Ultra-high resolution, 1" silk dome tweeter for ultimate sound reproduction
- Long-throw 8" woofer with deformation-resistant glass fiber cone
- Adjustable to a wide range of acoustic conditions and subwoofer operation
- Separately controlled limiter for low and high-frequency overload protection
- Servo-balanced inputs with XLR, TRS and unbalanced RCA connectors
- High-density composite enclosure for ultra-low diffraction and reduced low-frequency distortion
- "Planet Earth" power supply for maximum flexibility (100 - 240 V~), noise-free audio, superior transient response plus low power
- 3-Year Warranty Program\*\*
- Conceived and designed by BEHRINGER Germany



The 150-Watt NEKKST K8 Studio Monitor's unparalleled, world-class performance is the result of a major collaboration between BEHRINGER audio engineers and loudspeaker master-designer/founder of KRK – Keith R. Klawitter. This incredible reference system is ideal for all critical listening environments thanks to the custom-engineered bi-amplification system that features separate amplifiers for the 8" glass-fiber woofer and 1" silk-dome tweeter. K8's long-throw woofer generates deep, tight bass and virtually smear-proof mids, while the ultra-high resolution tweeter provides sparkling highs – all enhanced by Keith's Advanced Waveguide Technology for an extremely generous sweet spot.

## My Best Work Yet

Ever since founding KRK more than 25 years ago, I have devoted my life to creating the industry's best-sounding studio loudspeakers. I was very excited when BEHRINGER asked me to design their new reference monitors. They gave me complete freedom to use the finest materials and apply my lifetime of knowledge in monitor design. Now, after two years and countless hours of intense design and listening, I have achieved that goal. I am proud of the NEKKST Reference Monitors.

My best work yet.

Keith R. Klawitter



Keith R. Klawitter received numerous Awards and provided the main mixing monitors for multiple Academy Awards and Grammy Awards shows. He completed custom projects for high-profile clients including Michael Jackson, Aaron Spelling and Steely Dan, plus worked with representatives for Paul McCartney, the Rolling Stones, Eric Clapton, Metallica, and numerous other internationally recognized artists.

\*All third-party trademarks are the property of their respective owners. Their use neither constitutes a claim of the trademark nor affiliation of the trademark owners with MUSIC GROUP. Product names are mentioned solely as a reference for compatibility, effects and/or components.

\*\*Warranty details can be found at music-group.com.

## Studio Monitors

# NEKKST K8

Audiophile Bi-Amped 8" Studio Monitor with  
Advanced Waveguide Technology



## Why Studio Monitors are so Important

The goal of a great studio monitor is to present an accurate representation of your mix, so you can tell how well it will translate to the diverse listening environments and systems of today, such as car stereos, club sound systems, radio, portable digital music players and others. The remarkably-flat response of the NEKKST K8 allows you to work with the complete confidence that your mixes will “play” accurately on these systems and to your audience at large.

## Bi-Amplification - The Path to Absolute Signal Integrity

With its 150 ultra-clean Watts of output, delivered through separately-powered drivers via a true bi-amping mode with 2 amplifiers per speaker, the K8 delivers high-resolution sound that really brings out the best in your music. You will notice that most competitors apply simple passive crossovers, which not only inaccurately separate the frequency spectrum, but most importantly impact the drivers’ performance. BEHRINGER has gone the extra mile, driving each woofer and tweeter with a separate amplifier for absolute signal integrity.

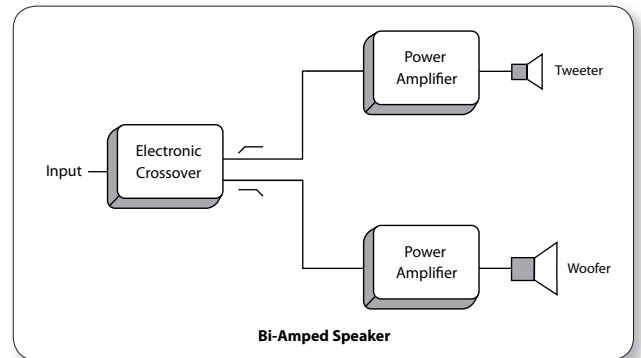

## Thoughtful Design

The ultra-linear, 150-Watt reference-class NEKKST K8 was designed by renowned acoustic icon and founder of KRK, Keith R. Klawitter – a man who has devoted much of his life to the quest for the “perfect” loudspeaker. The K8 features Keith’s advanced Waveguide technology for the ultimate in acoustic dispersion, which generates an extremely large “sweet zone” for easy and optimal monitoring. A true bi-amped system, an ingenious crossover design and separate amplifiers are utilized for high and low-frequency signals, providing superb sound reproduction from the long-throw, deformation-resistant, glass-fiber cone woofer and pristinely-accurate, silk-dome tweeter. The NEKKST K8 not only satisfies seasoned engineers and producers, but makes audiophile-level sound accessible to both home and professional recording studio applications. Keith Klawitter wrote the book when it comes to modern studio monitors, and to quote the monitor-master, “This is my best work yet!”

Studio Monitors

# NEKKST K8

Audiophile Bi-Amped 8" Studio Monitor with Advanced Waveguide Technology

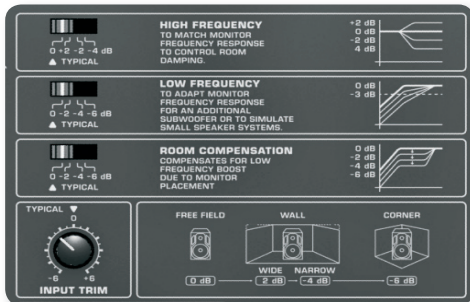

## Environmentally Friendly

The ability for a studio monitor to adapt to a wide range of acoustic conditions is of paramount importance, and the NEKKST K8 delivers extreme versatility in this arena. K8's rear panel features switches for adjusting high and low-frequency response, compensating for varying room attributes, or for pairing with a dedicated subwoofer. Independently-controlled limiters protect both the woofer and tweeter against overload.

## Connectivity and Compatibility

Since a monitor's output is only as good as its input, the NEKKST K8 includes a servo-balanced front end and accepts XLR, TRS and unbalanced RCA connectors for extremely-flexible connectivity. The high-density composite enclosure guarantees ultra-low diffraction and reduced low-frequency distortion.

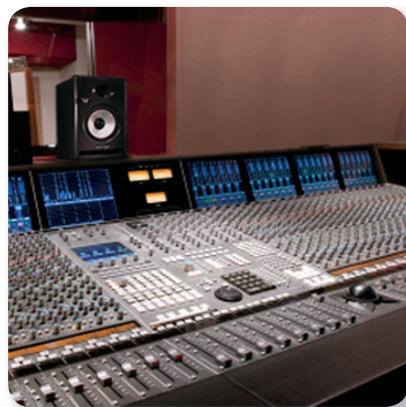

## Unparalleled Accuracy

The audiophile-grade NEKKST K8 is the ideal tool for crafting mixes that translate perfectly across the widest possible spectrum of audio playback devices. Thanks to Keith Klawitter's custom-engineered bi-amp system driving an Advanced Waveguide-mounted 8" glass-fiber woofer and 1" silk-dome tweeter, you get deep, tight bass with virtually smear-proof mids and sparkling highs – all in an extremely generous sweet spot! With the K8's comprehensive suite of options and features, this audiophile-grade monitor delivers, no matter what your listening environment.

A true collaboration between Keith R. Klawitter (Mr. KRK) and BEHRINGER, NEKKST Studio Reference Monitors deliver unparalleled accuracy – audition a pair at your dealer today.

Studio Monitors

# NEKKST K8

Audiophile Bi-Amped 8" Studio Monitor with  
Advanced Waveguide Technology

## You Are Covered

We always strive to provide the best possible Customer Experience. Our products are made in our own MUSIC Group factory using state-of-the-art automation, enhanced production workflows and quality assurance labs with the most sophisticated test equipment available in the world.

As a result, we have one of the lowest product failure rates in the industry, and we confidently back it up with a generous [3-Year Warranty program](#).



Studio Monitors

# NEKKST K8

Audiophile Bi-Amped 8" Studio Monitor with  
Advanced Waveguide Technology

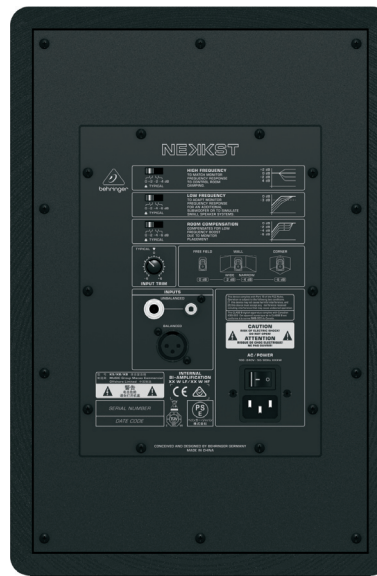



Studio Monitors

# NEKKST K8

Audiophile Bi-Amped 8" Studio Monitor with  
Advanced Waveguide Technology



Studio Monitors

# NEKKST K8

Audiophile Bi-Amped 8" Studio Monitor with  
Advanced Waveguide Technology

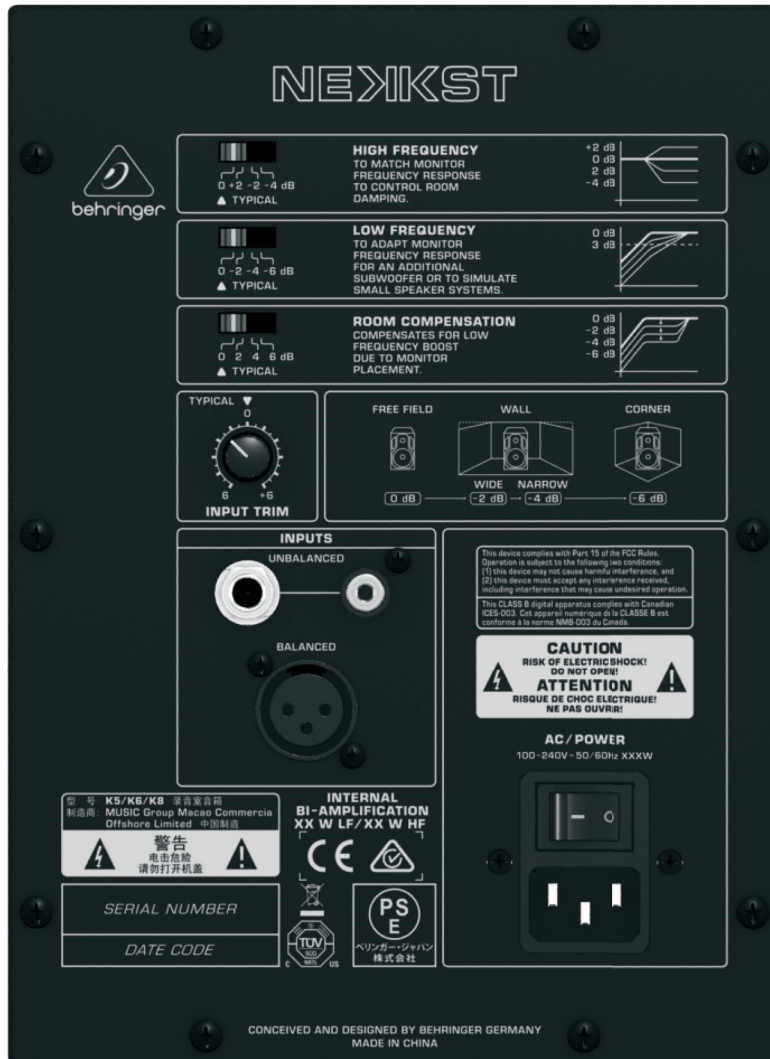

For service, support or more information contact the BEHRINGER location nearest you:

**Europe**  
**MUSIC Group Services UK**  
 Tel: +44 156 273 2290  
 Email: CARE@music-group.com

**USA/Canada**  
**MUSIC Group Services NV Inc.**  
 Tel: +1 702 800 8290  
 Email: CARE@music-group.com

**Japan**  
**MUSIC Group Services JP K.K.**  
 Tel: +81 3 6231 0454  
 Email: CARE@music-group.com

MUSIC Group accepts no liability for any loss which may be suffered by any person who relies either wholly or in part upon any description, photograph, or statement contained herein. Technical specifications, appearances and other information are subject to change without notice. All trademarks are the property of their respective owners. MIDAS, KLARK TEKNIK, TURBOSOUND, BEHRINGER, BUGERA and DDA are trademarks or registered trademarks of MUSIC Group IP Ltd. © MUSIC Group IP Ltd. 2014 All rights reserved.

