

PM85H

PROFESSIONAL VOCAL CONDENSER MICROPHONE



SOUNDS COOL

IMPORTANT PRECAUTIONS

- 1) Read all documentation before operating your equipment.
- 2) Retain all documentation for further reference.
- 3) Do not connect/disconnect any microphone when the Phantom is already activated.
- 4) The diaphragm is the most sensible part of the microphone and it must be left untouched to preserve its original performances. Do not spray any substance, like hair spray, directly into the microphone and avoid getting make-up or paint on the microphone element and its housing.
- 5) Despite the resistant materials we use, please keep your microphones away from any kind of unnecessary exposure to water and high humidity, moisture and sweat.
- 6) Keep the microphone element dry at all times. The protection grid may be cleaned with distilled water. Avoid all kinds of spray or fluids, which contain chemical components to remove static electricity on or close to the microphone as this could cause damage to the electret layer.
- 7) Mounting the microphone close or directly on the skin of a performer, be careful to avoid sweat from running directly into the microphone. If the microphone has been exposed to sweat it must be rinsed out in distilled water and left to dry out to recover its original specifications. Drying out your microphone between exposures to humidity will also help to extend its lifetime.
- 8) If the microphone gets filled up with water it will not be damaged, but possibly turn deaf while the water is captured inside the microphone, behind the protection grid. Remove the water by shaking the microphone or drying it with a piece of lint free cloth.
- 9) Use of windscreen is recommended also using your microphone in dirty or dusty environments.
- 10) Exposing the microphone to make-up or dusty materials, the grid could get clogged. Remove the microphone grid from the microphone body and clean the grid using a soft cloth with few drops of distilled water only. Make sure the grid is dry before remounting it on the microphone element.
- 11) When not in use, the microphone should be disconnected and stored in the supplied case.
- 12) The cable is usually longer than required for its actual purpose. Ensure that superfluous cable is wound up in large soft loops. Residue from dust, glue or tape on the cable must be removed after use. The cable can easily be cleaned using organic oil (i.e. olive oil) or distilled water. Do not bend the cable or rub it harshly since this may stress the strands of the cable and cause them to break over time.

WARNING

In order to protect your own and others' safety and to avoid invalidation of the warranty of this product, please read this section carefully before operating this product.

PACKAGE CONTENTS

- Microphone
- Plastic carrying case
- Balanced XLR cable
- Microphone clip
- Owner's manual
- Warranty certificate

INTRODUCTION

First of all, thank you for choosing a product **FiveO by Montarbo®**. This line has been designed for those who want to set-up their user friendly audio sound system with excellent performances and outstanding value. Furthermore, we manufactured all these products to assure you satisfying and reliable operation over many years.

Our **PM85H** is a professional vocal microphone, based on Back-Electret condenser technology. This Phantom powered microphone has been designed to provide to your voice the best performances both in live and in studio applications. Please, in order to enjoy each feature of your new microphone thus achieving the best sonic performances, take a few moments to carefully read these instructions.

For further information about your microphone, please check our website www.fiveo.it, or send an email to: mail@fiveo.it

FEATURES

Being aware of the heavy use your **PM85H** microphone should run in most demanding applications, we manufacture it in a sturdy way, with a rugged stage grill design to offer excellent protection against the rigours of touring. The cardioid polar pattern minimizes undesired background noise pick-up. Your **PM85H** is characterized by a frequency response and a capability to manage high SPL, which make it perfect for drums and wind instruments.

- Sound character tailored for clear pick-up of female and male voice.
- The wide frequency response allows you to use it for most studio and live applications.
- Its capacity to handle high sound pressure levels together with its low THD make it a perfect mate for most demanding application.

OPERATIONS

To properly work, your **PM85H** needs Phantom power from your mixer and/or preamp; activate the Phantom power immediately after connecting all the microphones to your mixer. Don't connect microphones to the mixer (or the stagebox/wallbox) as long as the phantom power supply is switched on! In order to prevent switch-on "thump" or "pop", please mute your sound system before activating the phantom power supply, then wait for several seconds before turning on your sound system.

Please, be careful handling your **PM85H**. Despite the ruggedness of our manufacture, the internal diaphragm is very thin and it could suffer for mechanical shocks and for excessive moisture. In order to avoid dust collecting over the capsule, we suggest you to use the supplied plastic carrying case for microphone storage too.

We supply your **PM85H** with a perfectly shaped clamp allowing easy and comfortable positioning on standard mic booms. On stage use, please be careful to wedge monitor placement; despite the **PM85H** has a cardioid pattern, it should have feedback with very high sound pressure level!

Finding the optimal microphone placement is basically a process requiring trials; so make your own experience starting from mic tech specs and your knowledge, continuously using your musical sensibility and your ears. Don't forget that every ambient has its own sonic character, so every time you've to change some settings. We suggest to use your **PM85H** at different distances from each sound source. Let's say 3-5 cm. (1"-2") is good for most vocal use, closer you should experience some proximity effect, boost of lower frequencies, increasing the distance you risk feedback and instruments pick-up. The distance can be raised to 10-15 cm. (4"-6") for acoustic guitar and other musical instrument, like drum kit toms or snare drum.

POLAR PATTERN
Cardioid

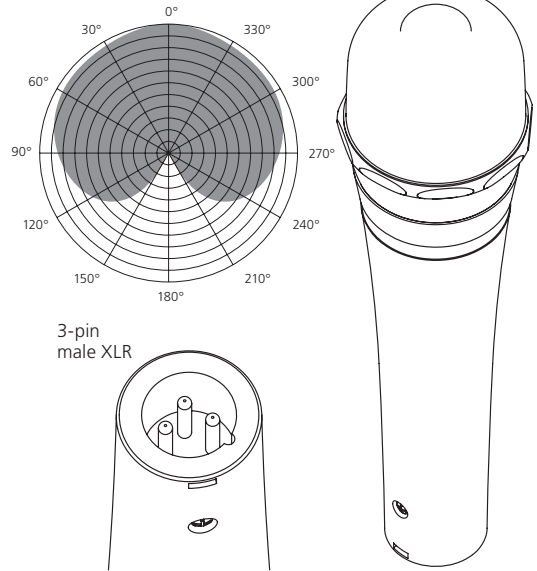

WEEE | Waste from Electrical and Electronic Equipment ATTENTION!



The crossed out wheeled bin symbol that can be found on this product means that the product is covered by the Waste from Electrical and Electronic Equipment Directive. The symbol is intended to indicate that waste from electrical and electronic equipment must be subject to a selective collection. For more details on available collection facilities please contact your local government office or the retailer where you purchased this product. The solid bar underneath indicates that the product has been put on the market after 13th August 2005.

INFORMATION ON PROPER DISPOSAL

Information on Disposal for Users (private households)

In the European Union | Attention: If you want to dispose of this equipment, please do not use the ordinary dust bin! Used electrical and electronic equipment should not be disposed of via the normal household waste stream but must be treated separately and in accordance with legislation that requires proper treatment, recovery and recycling of used electrical and electronic equipment. Following the implementation by member states, private households within the EU states may return their used electrical and electronic equipment to designated collection facilities free of charge*. In some countries* your local retailer may also take back your old product free of charge if you purchase a similar new one. *Please contact your local authority for further details.

In other Countries outside the EU | If you wish to dispose of this product, please contact your local authorities and ask for the correct method of disposal.

In Switzerland | Used electrical or electronic equipment can be returned free of charge to the dealer, even if you don't purchase a new product. Further collection facilities are listed on the homepage of www.swico.ch or www.sens.ch.

Information on Disposal for Professional Users

In the European Union | If the product is used for business purposes and you want to discard it: please contact your FiveO by Montarbo® dealer who will inform you about the take-back of the product. You might be charged for the costs arising from take-back and recycling. Small products (and small amounts) might be taken back by your local collection facilities.

In Spain | Please contact the established collection system or your local authority for takeback of your used products.

In other Countries outside the EU | Please contact your local authorities and ask for the correct method of disposal.

TECHNICAL SPECIFICATIONS

Transducer type	Back-Electret Condenser Microphone
Polar pattern	Cardioid
Power Supply	+48V DC
Frequency response	50Hz ÷ 18kHz ±3dB
Sensitivity in free field	-45dB ±3dB (0dB=1V/Pa @1kHz)
THD	<0.5% up to 110dB
S/N ratio	70dB
Dynamic range	118dB
Output Impedance	200Ω @1kHz ±30%
Connector	3-pin male XLR
Dimensions	Ø48mm x 186mm (1.3/4" x 7.3")
Net weight	310g (0,68 lbs)

FREQUENCY RESPONSE

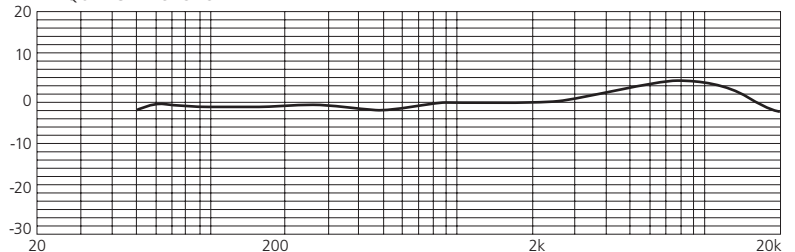

The information contained in this manual have been carefully drawn up and checked. However no responsibility will be assumed for any incorrectness. This manual cannot cover all the possible contingencies which may arise during the product installation and use. Should further information be desired, please contact us or our local distributor. Elettronica Montarbo srl can not be considered responsible for damages which may be caused to people and things when using this product. Specifications and features are subject to change without prior notice.

The product is made in China under license of Elettronica Montarbo srl.
The product is compliant with the EU legislation.



Elettronica Montarbo srl
via G. di Vittorio 13 | 40057 Cadriano Granarolo Emilia (BO) ITALY
T +39 051 6047711
F +39 051 765226
@ mail@fiveo.it
www.fiveo.it



Company under the control of EKO Music Group SpA

©2012 Elettronica Montarbo srl | Printed in China