

## WHAT'S IN THE BOX

- goRack Performance Processor
- Power Adapter

## REGISTER YOUR PRODUCT

Register your product at [http://dbxpro.com/en-US/support/warranty\\_registration](http://dbxpro.com/en-US/support/warranty_registration).



Scan codes with a QR scanner app on your mobile device to go straight to web URLs.

## GET THE OWNER'S MANUAL

Get the owner's manual at <http://dbxpro.com/en-US/products/gorack#documentation>.



### 1 Connect the goRack

- Turn down your amp or powered speaker levels then power off your system.
- Make connections, power on the goRack, then power on your system.

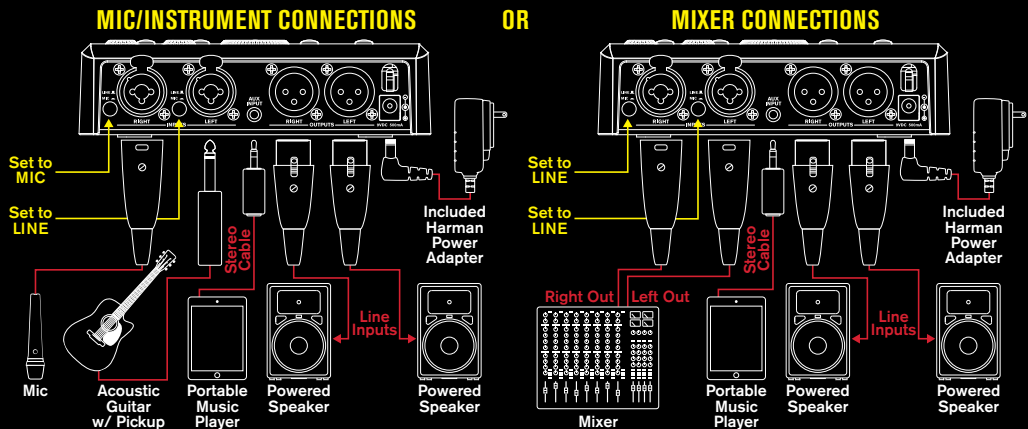

### 2 Select Routing mode and set levels

- Press and hold the **MUTE (MODE)** button for 2 seconds until the button begins to flash. Use the **VOLUME (EDIT)** knob to select the best routing option for your system (see 3 and the back of the goRack for routing option information). Press any button to exit Routing mode.
- Turn the **VOLUME** knob to 70.
- With signal present, adjust the **LEFT** and **RIGHT** knobs until the **INPUT SIGNAL** LEDs occasionally light orange.
- Turn up the volume on your amp or powered speakers to the desired level. Future system level adjustments can be made using the goRack's **VOLUME** encoder if required.

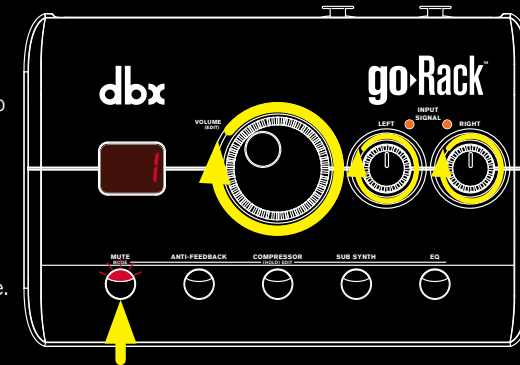

### 3 Routing modes

- 1 MONO** – Use this option when using the goRack as a portable 2-channel mixer. Perfect for solo/duo artist performance or speech.
- 2 STEREO** – Maintains the stereo image and is best suited when using the goRack between a mixer and powered speakers or amplifier(s).
- 3 ADVANCED** – Similar to #2 STEREO option but sums the MIC/LINE inputs to mono and offers Sub Synth and EQ on the AUX INPUT signal.

**LEGEND**  
AF = Anti-Feedback  
COMP = Compressor  
SUB = Subharmonic Synthesiser  
EQ = Equalizer

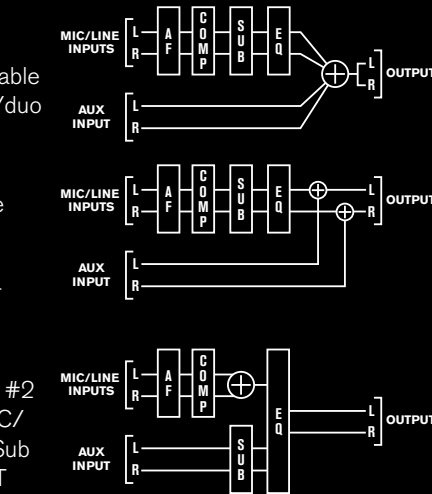

#### 4 Enable processing

- Press each button to enable/disable each processor type.  
LED on = processor enabled  
LED off = processor disabled
- See the owner's manual or bottom of the goRack for a list of EQ curves, Anti-Feedback setting descriptions, and other helpful information.

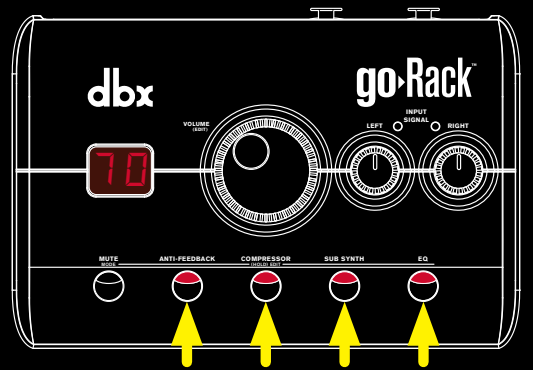

#### 5 Edit settings

- Press and hold a processor button for 2 seconds to edit its setting (the button's LED will flash to indicate Edit mode is enabled).
- Turn the **VOLUME (EDIT)** knob to edit the setting.
- When done, press any button to exit Edit mode.
- Enjoy! Thanks for choosing dbx.

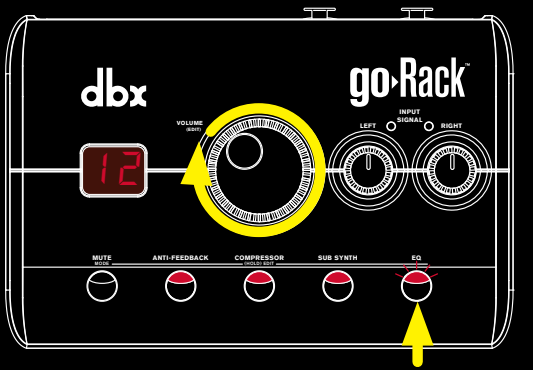

• 801.566.8800 • dbxpro.com

goRack Quick Start Guide  
PN: 5061659-B



# Quick Start Guide