

280W BEAM & SPOT MOVE HEAD LIGHT



Please read over this manual before operation the light

1. Maintenance

- To reduce the risk of electrical shock or fire, do not expose this unit to rain or moisture.
- Intermittently using will extend this item's service life.
- Please clear the fan ,fan net , and optical lens in order to keep good work state.
- Do not use the alcohol or any other organic solvent to wipe the shell.

2. Statement

The product has perfect performance and integrity packing. All users should be strictly complying with the warning and operating instructions as stated. Or we aren't in charge of any result by misusing. Any damage resulting by misuse is not within the Company's warranty. Any fault or problem caused by neglecting the manual is also not in the charge of dealers.

Note: All information is subject to change without prior notice.

3. Safety Precaution

- In order to guarantee the product's life, please don't put it in the damp places or even the environment over 60degrees.
- Always mount this unit in safe and stable matter.
- Install or dismantle should operate by professional engineer.
- Using lamp, the change rate of power voltage should be within $\pm 10\%$, If the voltage is too high, it will shorten the light's life; If it's not enough, will influence the effect.
- Please restart it 20 minutes later after turning off light , until full-cooling. Frequent switching will reduce the life span of lamps and bulbs; intermittent using will improve the life of bulbs and lamps.
- In order to make sure the product is used well, please read the Manual carefully.

4. Product Instruction

- lamp: 280W (Color temperature: 8000K)
- Channel mode: 16 / 24 DMX512 Channel
- Pan scan: 540°(16bit) Electric correction
- Tilt scan: 270° (16bit) Electric correction
- Amazing dot matix, four tact switch, 180° turning show

- Color wheel: one color wheel, 13 kinds of color chips in one color wheel
- Static Gobo: 14gobos
- Rotation Gobo:9 gobos
- Effect Wheel: one Rotation eight prism,one Rotation six prism effect move , frost
- 0-100% mechanical dimming, mechanical dimming and free dimming available.
- strobe macro control available.
- Lens optical system achanical focus .beam angle3.8°-20°
- Over heat protection
- Power Input: 100-240V, 50/60Hz
- Power Dissipation: 420W
- IP level :IP20
- Magnetic ballast and AC/Dc power supply
- Packing Size: 523x337x570mm
- Net weight: 20 KG

5. Cable connection (DMX)

Use a cable conforming to specifications EIA RS-485: 2-pole twisted, shielded, 120Ohm characteristic impedance, 22-24 AWG, low capacity. Do not use microphone cable or other cable with characteristics differing from those specified. The end connections must be made using XLR type 3 or 5-pin male/female connectors. A terminating plug must be inserted into the last projector with a resistance of 120Ohm (minimum 1/4 W) between terminals 2 and 3.

IMPORTANT: The wires must not make contact with each other or with the metal casing of the connectors. The casing itself must be connected to the shield braid and to pin 1 of the connectors.

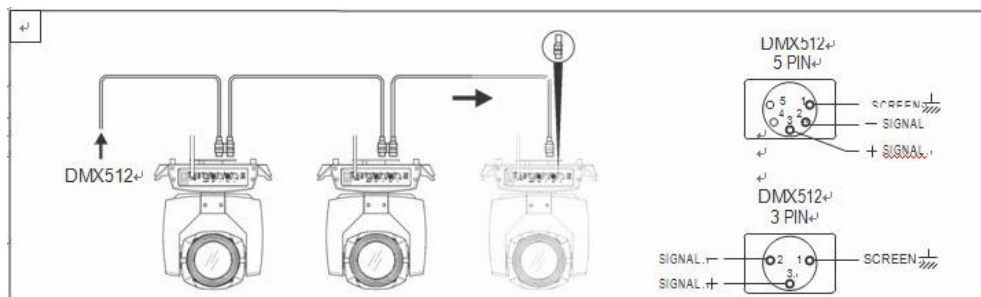

Figure 1 DMX Cable connection

6. Rigging (Optional)

This equipment can be positioned and fixed by clamp in every direction of the stage. Locking system makes it easy to fasten to the bracket.

Attention! Two clamps is needed to fix the equipment. Every clamp is locked by fastener of 1/4 kind. Fastener can only be locked clockwise.

Attention! Fasten a safety string to the additional hole of side aluminum piece. The secondary accessory can not hang on the delivery handle. Nip the equipment on bracket.

- Check if rigging clamp (not including the one inside) damaged or not? If stand ten times weight as the equipment. Make sure the architecture can stand ten times weight as all the equipment, clamps, wiring and other additional fixtures.
- Screws for clamping must be fixed firmly. Take one M12 screw (Grade 8.8 or higher) to clamp bracket, and then screw the nuts.
- Level the two hanging points at the bottom of clamp. Insert fastener to the bottom, lock the two levers by 1/4 rotating clockwise; then install another clamp.
- Install on safety string which stands at least ten times weight as equipment. Terminal of the accessory is designed for clamps.
- Make sure pan/tilt lock unlocked or not. Keep the distance more than 1M from equipment to flammable material or lighting source.

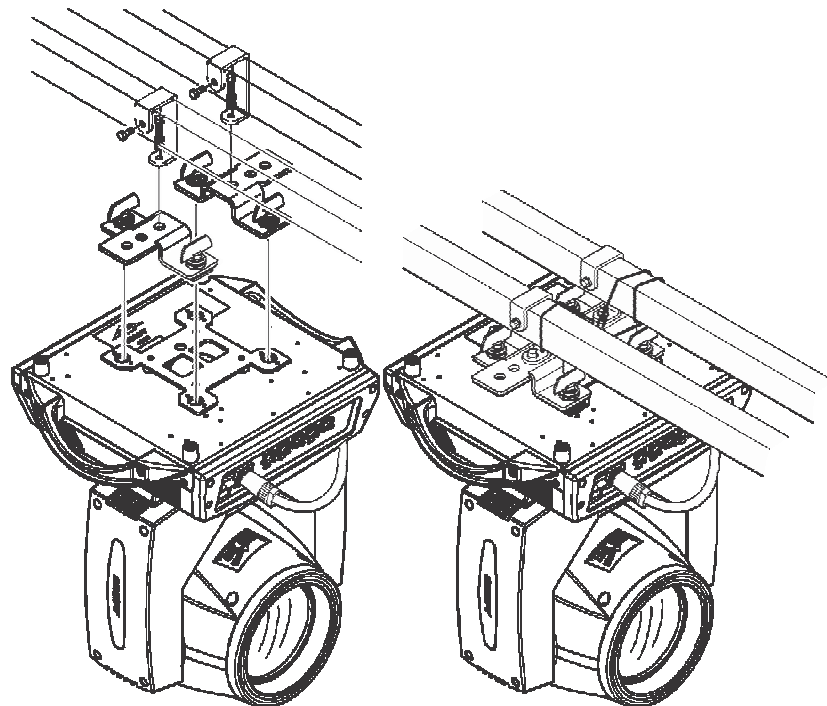

7. MENU FUNCTION:

DMX Address	001-512		
RUN MODE	DMX 16 channel		
	DMX 24 channel		
	Auto Run		
	Sound Control		
	Master/Slaver mode		
	Light Switch	sure	
		no	
	Channel Qty	simple	
	expand		
Display Setting	language	中文	
		English	
	Screen Saver	mode 1	
		mode 2	
		mode 3	
		off	
	Screen Rotation	on	
		off	
	Touch Enable	on	
		off	
Touch Rectify			
Test	Pan		
	Tilt		
	Focus		
	Color		
	Gobo		
	Prism		
	Frost		
	Strobe		
Advanced setup	Pan invert	on	
		off	
	Tilt invert	on	
		off	
	P/T rectify	on	
		off	
	Pan Offset		

	Tilt Offset		
	lamp up when	reset done	
		power on	
		manual	
	Factory setting	sure	
		no	
Statue setup	work mode		
	address		
	version		
	elapse		
	total		
	DMX clr		
	Sys Rst		

8 . Function Mode

1. Set DMX Address

Click and select the "ADDR", can enter the page of DMX address setting, range from 1 to 512, the address code shouldn't is not greater than (512- channels quantity), otherwise the light will not been controlled. Following is the operation:

Enter the page of DMX address, click the blank area in right side of display will pop-up diglog as in Fig. 4, modify value, then click 'ENTER' to confirm and save DMX address code.

2. Set Light work mode

Enter the page of 'WORK MOD' and modify setting. Can set light work mode, control lamp and DMX channel mode..

Light includes 3 work mode: DMX MODE, AUTO RUN and SOUND MODE, Parameter definition as following:

- **DMX Mode:** Under this mode, the light receive data from the DMX controller and move.
- **AUTO RUN:** Under this mode, light will run with inside code(data), ignore data from DMX controller.
- **SOUND Ctrl:** Under this mode, light ignore data from DMX controller., When there is a strong sound in stage, the light will run a scene, otherwise it will keep the last scene.
- **M/S Choose:** 'M/S Choose' is available when light just in 'AUTO RUN' or 'SOUND Ctrl' mode. If this item is set as 'OFF', the light don't send data to other light via DMX Cable. When 'ON', the data will send to other slave light immediately.
- **Lamp control:** Turn on lamp when this item is set 'ON', otherwise, turn off lamp. The gap between operation is limited to 30 second.
- **Channel mode:** Light support 2 DMX Channel mode: sample or extend.

3. Set display

Light support 2 language, rotation display, Enter page to set parameter following:

- **Language:** Select display as simplified Chinese or English.
- **Screen Saver:** when panel is idle(these is no operation in 10 second), displayer will enter saver status. When set as 'mode 1', saver status is close display, as 'mode 2' saver status will display DMX address code(DMX MODE) or display LOGO(AUTO RUN or SOUND CTRL). As 'OFF', keep light up display and show main menu.
- **Screen Rotation:** rotate display.
- **Touch enable:** Disable or enable touch function, when disable, use encoder to operate light and set parameter.
- **Touch adjust:** adjust touch function, normally, not enter this item.

4. Test light

Enter the page , Light will into test mode, in this mode, the light does not receive the data for DMX controller.:

- PAN: range for 0 to 255;
- TILT: range for 0 to 255;
- FOCUS: range for 0 to 255;
- COLOR: range for 0 to 255;
- GOBO: range for 0 to 255;
- PRISM: range for 0 to 255;
- FROST: range for 0 to 255;;
- STROBE: range for 0 to 255;。

5. Set light run parameter

Enter the page, set the parameter of light:

- Pan Invert: Reverse PAN move.
- Tilt Invert: Reverse TILT mover.
- Rectify enable: set as 'OFF', PAN or TILT will disable position rectify function. As 'ON', when PAN or TILT lose steps, light will rectify auto.
- Pan Offset: Set PAN original position.
- Tilt Offset: Set TILT original position.
- Lamp up when: Select lamp on mode, includes 3 mode: power on, after reset done and manual;
- Factory setting: restore all parameter to factory setting.

6. View status

Enter the page :

- View light current status, version;
- DMXClr: Click to clear all DMX data to '0'.
- SysRst: Click to reset light.

9. DMX CHANNELS

CH NO		Name	value	Function
1	2			
1	1	X	0~255	Pan movement by 540°
2		X fine	0~255	Fine Pan
3	2	Y	0~255	Tilt movement by 270°
4		Y fine	0~255	Fine Tilt
5	3	XY speed	0~255	Speed from max. to min. (vector mode)
6	4	power/macrob	0~129	empty
			130~139	Lamp On, reset (total reset except pan/tilt reset)
			140~149	Pan/Tilt reset
			150~189	Effect motor reset
			200~209	Total reset

			210~229	empty
			230~239	Lamp Off
			240~255	empty
7	5	colour		
			0~8	Open/white (100%~10%)
			9~17	colour 1 (100%~10%)
			18~26	colour2 (100%~10%)
			27~36	Colour 3 (100%~10%)
			37~45	Colour 4 (100%~10%)
			46~54	Colour 5 (100%~10%)
			55~63	Colour 6 (100%~10%)
			64~72	Colour 7 (100%~10%)
			73~81	Colour 8 (100%~10%)
			82~90	Colour 9 (100%~10%)
			91~100	Colour 10 (100%~10%)
			101~109	Colour 11 (100%~10%)
			110~118	Colour 12 (100%~10%)
			119~127	Colour 13 (110%~10%)
			128~129	open/white
			130~134	Colour 1
			135~138	Colour 2
			139~143	Colour 3
			144~147	Colour 4
			148~152	Colour 5
			153~157	Colour 6
			158~161	Colour 7
			162~166	Colour 8
			167~171	Colour 9
			172~176	Colour 10
			177~180	Colour 11
			181~185	Colour 12
			186~189	Colour 13
			190~215	Forwards rainbow effect from fast to slow
216~217	open/white			
218~243	Backwards rainbow effect from slow to fast			
244~255	Auto random color selection from fast to slow			
8		Colour fine	0~255	Color wheel - fine positioning
9	6	speed	0~255	Speed of Rot. Gobo selection from max. to min.
10	7	Static gobo	0~3	Open/hole
			4~9	Gobo 1
			10~15	Gobo 2

			16~21	Gobo 3
			22~27	Gobo 4
			28~33	Gobo 5
			34~39	Gobo 6
			40~45	Gobo 7
			46~51	Gobo 8
			52~57	Gobo 9
			58~63	Gobo 10
			64~69	Gobo 11
			70~75	Gobo 12
			76~81	Gobo 13
			82~87	Gobo 14
			88~95	Shaking gobo 1 from slow to fast
			96~103	Shaking gobo 2 from slow to fast
			104~111	Shaking gobo 3 from slow to fast
			112~119	Shaking gobo 4 from slow to fast
			120~127	Shaking gobo 5 from slow to fast
			128~135	Shaking gobo 6 from slow to fast
			136~143	Shaking gobo 7 from slow to fast
			144~151	Shaking gobo 8 from slow to fast
			152~159	Shaking gobo 9 from slow to fast
			160~167	Shaking gobo 10 from slow to fast
			168~175	Shaking gobo 11 from slow to fast
			176~183	Shaking gobo 12 from slow to fast
			184~191	Shaking gobo 13 from slow to fast
			192~199	Shaking gobo 14 from slow to fast
			200~201	Beam
			202~221	Forwards gobo wheel rotation from fast to slow
			222~223	No rotation
			224~243	Backwards gobo wheel rotation from slow to fast
			244~255	Auto random gobo selection from fast to slow
11	8	Rotation gobo		
			0~4	Open/hole
			5~7	Gobo 1
			8~10	Gobo 2
			11~13	Gobo 3
			14~16	Gobo 4
			17~19	Gobo 5
			20~22	Gobo 6
			23~25	Gobo 7

			26~28	Gobo 8
			29~31	Gobo 9
			Rotation	
			32~34	Rotation gobo 1
			35~37	Rotation gobo 2
			38~40	Rotation gobo 3
			41~43	Rotation gobo 4
			44~46	Rotation gobo 5
			47~49	Rotation gobo 6
			50~52	Rotation gobo 7
			53~55	Rotation gobo 8
			56~59	Rotation gobo 9
			Shaking gobos	
			60~67	Shaking gobo 1 from slow to fast
			68~75	Shaking gobo 2 from slow to fast
			76~83	Shaking gobo 3 from slow to fast
			84~91	Shaking gobo 4 from slow to fast
			92~99	Shaking gobo 5 from slow to fast
			100~107	Shaking gobo 6 from slow to fast
			108~115	Shaking gobo 7 from slow to fast
			116~123	Shaking gobo 8 from slow to fast
			124~129	Shaking gobo 9 from slow to fast
			Rotation Shaking gobos	
			130~137	Rotation Shaking gobo 1 from slow to fast
			138~145	Rotation Shaking gobo 2 from slow to fast
			146~153	Rotation Shaking gobo 3 from slow to fast
			154~161	Rotation Shaking gobo 4 from slow to fast
			162~169	Rotation Shaking gobo 5 from slow to fast
			170~177	Rotation Shaking gobo 6 from slow to fast
			178~185	Rotation Shaking gobo 7 from slow to fast
			186~193	Rotation Shaking gobo 8 from slow to fast
			194~199	Rotation Shaking gobo 9 from slow to fast
			200~201	Open/hole
			202~221	Forwards gobo wheel rotation from fast to slow
			222~223	Open/hole
			224	Forwards
			225~243	Backwards gobo wheel rotation from slow to fast
			244~255	Auto random gobo selection from fast to slow
12	9	Gobo	rotation pattern channel set to index location	

		rotation	0~255	0~200°	
			When the rotation pattern is set to the stream channel		
			0	no rotation	
			1~127	Forwards gobo wheel rotation from fast to slow	
			128~129	no rotation	
		130~255	Backwards gobo wheel rotation from slow to fast		
13		空		no rotation	
14	10	prism	0~19	Open position (hole)	
			20~49	6-face linear rotating prism -indexing	
			50~75	6-face linear rotating prism- rotation	
			76~105	8-face circular rotating prism- Indexing	
			106~127	8-face circular rotating prism-rotation	
			Prism/gobo macros		
			128~135	Macro 1	
			136~143	Macro 2	
			144~151	Macro 3	
			152~159	Macro 4	
			160~167	Macro 5	
			168~175	Macro 6	
			176~183	Macro 7	
			184~191	Macro 8	
			192~199	Macro 9	
			200~207	Macro 10	
			208~215	Macro 11	
216~223	Macro 12				
224~231	Macro 13				
232~239	Macro 14				
240~247	Macro 15				
248~255	Macro 16				
15	11	Prism rotation	circular rotating prism- Indexing		
			0~255	0~200°	
			circular rotating prism-rotation		
			0	No rotation	
			1~127	Forwards prism rotation from fast to slow	
			128~129	No rotation	
130~255	Backwards prism rotation from slow to fast				
16	12	frost	0~127	Open/hole	
			128~255	frost	
17	13	zoom	0~255	Zoom from max. to min. beam angle	
18		Zoom fine	0~255	Fine Zoom	
19	14	focus	0~255	Continuous adjustment from far to near	

20		Focus fine	0~255	Fine Focus
21		空		N/A
22	15	shutter	0~31	Shutter closed
			32~63	Shutter open
			64~95	Strobe-effect from slow to fast
			96~127	open
			128~159	Opening pulse in sequences from slow to fast
			160~191	open
			192~223	Random strobe-effect from slow to fast
			224~255	open
23	16	dimmer	0~255	0~100%dimmer
24		空		N/A

