

# Instruction Manual

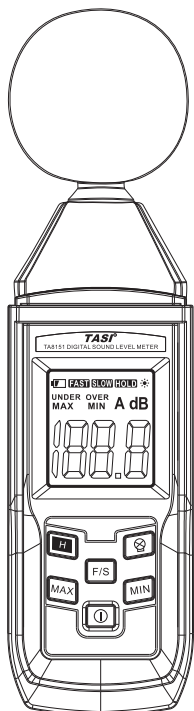

SUZHOU TASI ELECTRONICS CO.,LTD.

Version:TA8151 EN-02

Thanks for choosing the product of our company,thank you very much. Before using our product, please read the instruction manual carefully which will show you the correct way to operate. We wish that will help you experience the excellent performance of our product.

### A. Introduction

TA8151 sound level meter has been designed to meet the measurement requirement of Safety Engineers, Health, Industrial Safety offices and Sound Quality control in various environment, which include factory, office, traffic, family,and audio system.

This equipment adopts unique appearance design, beautiful and elegant. The leading switch sound level range is designed,make you measure more fast and accurate.

### B.Safety Notice

It is designed according to the IEC651 TYPE2. Before using our product, please read the instruction manual carefully which will show you the correct way to operate. We wish that will help you experience the excellent performance of our product.

Operation Environmental Condition:

1. Below 1800 meters in height
2. Humidity: ≤80%RH
3. Operation temperature:0~40°C

Maintenance:

Use dry cloth to clean the unit, but never with any solvent.

### C.Functions

1. A Frequency weighting
2. F/S(Fast/Slow) selection
3. Maximum measuring
4. Minimum measuring
5. Reading hold function
6. Back light function
7. Sound level OVER or UNDER indication
8. Low power display
9. Automatic power off/Continuous measuring selection

### D.LCD Display

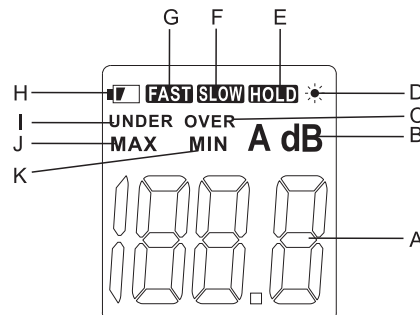

- A. Measuring value
- B. Frequency weighting
- C. Over the range
- D. Back light
- E. Reading hold function
- F. Slow
- G. Fast
- H. Low power indication
- I. Under the range
- J. Maximum
- K. Minimum

-1-

-2-

### E.Name and functions

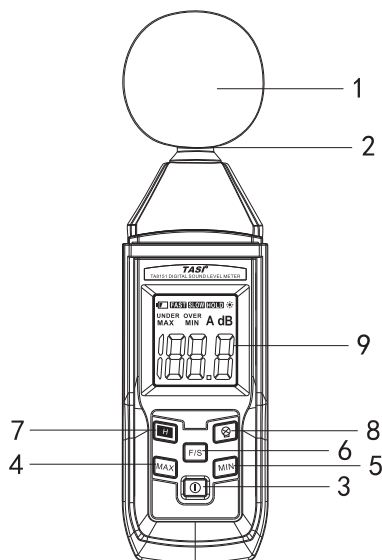

1. Wind screen
2. Electret condenser microphone
3. ON/OFF button
4. Maximum value hold button(MAX)
5. Minimum value hold button(MIN)
6. Fast/Slow selection button
7. Reading hold button
8. Back light button
9. LCD display

-3-

### F.Operation

1. Open the battery door and install 2 pieces AAA 1.5V batteries into the battery compartment. Cover the battery door.
2. Press ON/OFF button to enter automatic measuring mode, the sign "F" light. The reading will be changed according to the sound level of the current environment. If the sign "UNDER" or "OVER" light, the sound of the current environment is under 30dB or over 130dB.
3. Press F/S button to select the response speed, Fast or Slow. Press MAX button to lock the maximum sound level, the sound level will be locked until the higher value appears to replace. Press MIN button to lock the minimum sound level, the sound level will be locked until the lower value appears to replace. Press LIGHT button to turn on the LCD light or turn it off, back light will automatically off after 15 seconds.
4. Press power button to select ON/OFF.
5. Automatic power off: 15 minutes without operation.
6. Continuous measuring: If you need continuous measuring more than 15 minutes without operation, you should press F/S button first, and at the moment, press ON/OFF to open the equipment, the sign "COU" will light. This time it will be continuous measuring.
7. Low power indication: As the battery power is not sufficient, there would be a sign in the LCD indicating, replace the two AAA batteries.

### G.Specifications

- It is designed according to the IEC-651 TYPE2.
- Frequency range:31.5Hz ~ 8KHz
- Accuracy(1KHz): ±1.5dB(94dB@1KHz)
- Resolution:0.1dB
- Measuring range:30~130dB
- Display:4 digits with the maximum reading of 1999
- Frequency range:A
- Respond time:(Fast)0.5 second ; (Slow)1 second
- Microphone:1/2inch electret condenser microphone
- Power supply:1.5V AAA battery 2 PCS
- Operating condition:0~ + 40 °C , 10 ~ 80 % RH
- Storage condition:-10 ~ 60 °C , 10 ~70% RH
- Dimension:205 x 55 x 30mm
- Weight:Approx.98g(not including battery)
- Accessories:Windscreen,battery,carry bag,instructions.

-4-

### H.Caution

1. Do not operate the unit at high temperature and high humidity environment.
2. Please take out battery from unit if not in use for any extended period of time.
3. When using the unit in the presence of wind, mount the windscreen to avoid to pick up undesired signals.
4. As the battery power is not sufficient, there would be a sign in the LCD indicating, please replace the two AAA batteries timely.
5. After a long time, measurement accuracy will be reduced, and then it needs correction. Our products are all well calibrated before shipment. Recommended recalibration cycle is one year. This needs calibration standard sound source, professional correction software and specific methods, please contact with our company.

### Special Statement

- a. Used batteries must be in accordance with local laws and regulations to deal with!
- b. The Company reserves the right to update and modify the design of the product specifications and manual contents are subject to change without prior notice!



-5-