

TG D50

Dynamic Microphone



TG D50 with MKV 99 microphone clamp



LIN / EQ switch at the bottom

FEATURES

- Cardioid polar pattern
- Integrated elastic suspension
- Rugged design
- Excellent impulse fidelity
- Switch for frequency response: LIN (linear) and EQ (equalizer)

APPLICATIONS

The dynamic TG D50 microphone is exceptionally useful for miking drums. At the bottom there is a switch to select between LIN (linear) and EQ (Equalizer) frequency responses. If the switch has been set to LIN, the microphone can be used for miking toms, snare and other instruments. If the switch has been set to EQ, the microphone can be specially used for kick drums, supplying an appropriate frequency response and balanced sound without complicated settings on the mixing console. By using the ST 99 stand the microphone can also be placed inside the kick drum. The mass-reduced special diaphragm supplies absolute impulse fidelity and high gain before feedback.

VERSION

TG D50 Dynamic drum microphone for lower pitched instruments, cardioid, incl. MKV 99 microphone clamp. . Order # 707.430

TECHNICAL SPECIFICATIONS

Transducer type Dynamic
Operating principle Pressure gradient
Polar pattern Cardioid
Frequency response:
Close miking (switch position LIN) . . . 50 - 17,000 Hz
Close miking (switch position EQ) . . . 20 - 15,000 Hz
Distant miking (switch position LIN,
measured at 1 m) 80 - 17,000 Hz
Open circuit voltage
(switch position LIN) 2.4 mV/Pa (-52.5 dBV) \pm 3 dB
Open circuit voltage
(switch position EQ) 0.9 mV/Pa (-60.9 dBV) \pm 3 dB
Nominal impedance
(switch position LIN) 600 Ω
Nominal impedance
(switch position EQ) 200 Ω
Load impedance \geq 2 k Ω
Connection XLR, 3-pin, male
Dimensions:
Length 104 mm
Shaft diameter 24 mm
Head diameter 41 mm
Weight:
without clamp 134 g
with clamp 189 g

OPTIONAL ACCESSORIES

BMC 05 FM Standard microphone cable
XLR-XLR, length 5 m Order # 434.787
BMC 10 FM Standard microphone cable
XLR-XLR, length 10 m Order # 434.795
MKV 87 Patented clamp for drum rim,
3/8" Order # 459.356
MKV 99 Microphone clamp Order # 471.909
GST 590 Microphone stand 3/8",
height 0.34-0.60 m, Order # 418.765
with telescopic boom
ST 99 Miniature stand Order # 471.917

TG D50

FREQUENCY RESPONSE & POLAR PATTERN

This polar pattern and frequency response curve (± 3 dB) correspond to a typical production sample for this microphone.

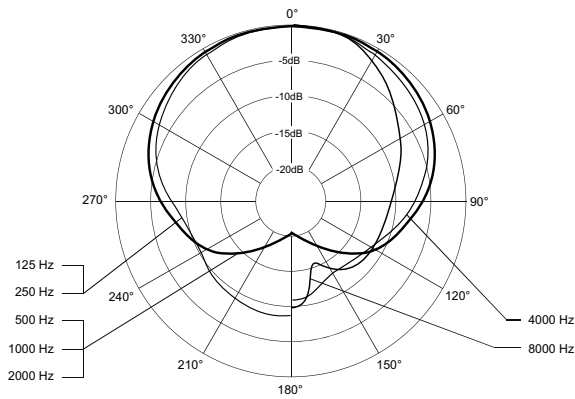
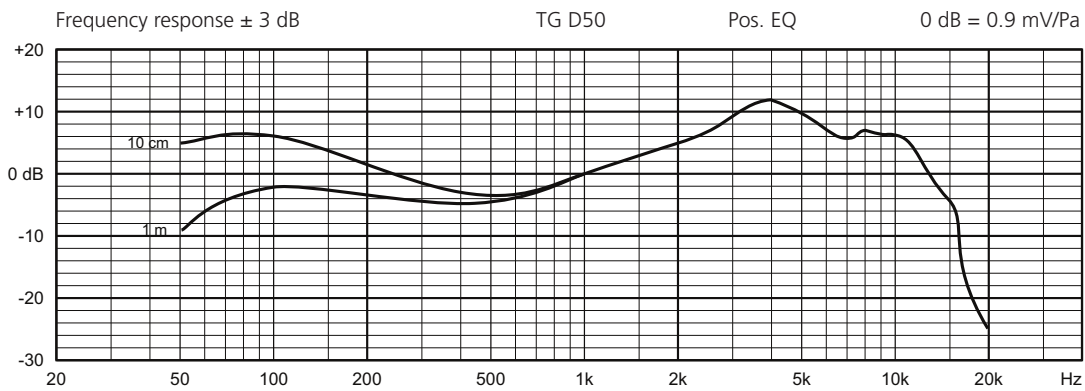
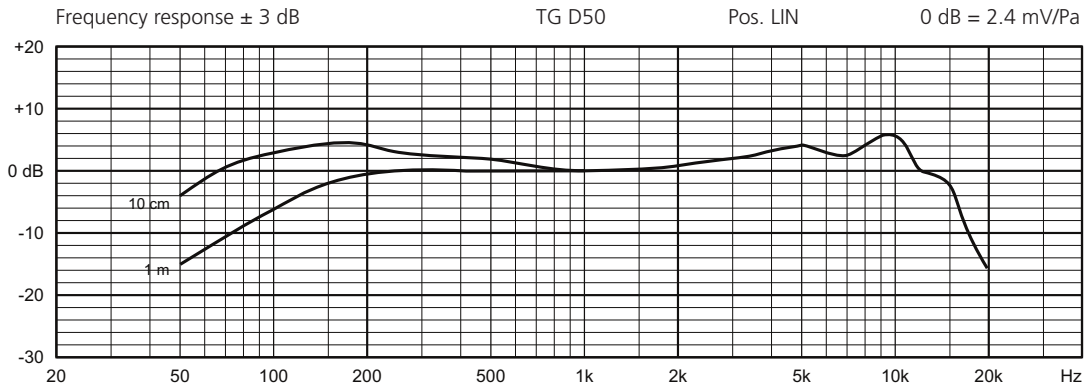

WIRING DIAGRAM

